



SLS SEMICONDUCTOR (SHENZHEN) CO.,LTD.

SOT-23 封装半导体晶体管/SOT-23 Plastic-Encapsulate Transistors

2SB624 (PNP)

用途/Applications :

用于功率放大电路，与 2SD596 互补。

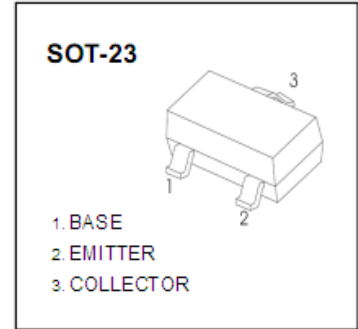

极限参数/Absolute maximum ratings(Ta=25°C)

参数/Parameter	符号/ Symbol	数值/Value	单位/Unit
集电极-基极电压/Collector-Base Voltage	V_{CB0}	-30	V
集电极-发射极电压/Collector-Emitter Voltage	V_{CE0}	-25	V
发射极-基极电压/Emitter-Base Voltage	V_{EB0}	-5	V
集电极连续电流/Collector Current Continuous	I_C	-0.7	A
集电极耗散功率/Collector Power Dissipation	P_C	0.2	W
结温/Junction Temperature	T_j	150	°C
储存温度/Storage Temperature	T_{stg}	-55~150	°C

电性能参数/Electrical characteristics (Ta=25°C)

参数	符号	测试条件	最小值	典型值	最大值	单位
集电极-基极击穿电压	$V_{BR(CB0)}$	$I_C = -100 \mu A, I_E = 0$	-30			V
集电极-发射极击穿电压	$V_{BR(CE0)}$	$I_C = -1mA, I_B = 0$	-25			V
发射极-基极击穿电压	$V_{BR(EB0)}$	$I_E = -100 \mu A, I_C = 0$	-5			V
集电极截止电流	I_{CB0}	$V_{CB} = -30V, I_E = 0$			-0.1	μA
发射极截止电流	I_{EB0}	$V_{EB} = -5V, I_C = 0$			-0.1	μA
直流电流增益	$h_{FE(1)}$	$V_{CE} = -1V, I_C = -100mA$	110		400	
直流电流增益	$h_{FE(2)}$	$V_{CE} = -1V, I_C = -700mA$	50			
集电极-发射极饱和压降	$V_{CE(sat)}$	$I_C = -700mA, I_B = -70mA$			-0.6	V
基极-发射极饱和压降	V_{BE*}	$V_{CE} = -6V, I_C = -10mA$	0.6		-0.7	V
特征频率	f_T	$V_{CE} = -6V, I_C = -10mA$		160		MHz
集电极输出电容	C_{ob}	$V_{CB} = -6V, I_E = -0, f = 1MHz$		17		pF

印章(Marking)& h_{FE} 分档(Classification of $h_{FE(1)}$)

范围/Range	110~180	135~220	170~270	200~320	250~400
印章/Marking	BV1	BV2	BV3	BV4	BV5



典型特性曲线图/Typical Characteristics

