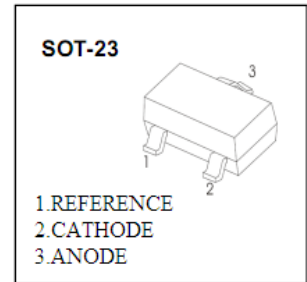
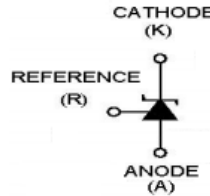

**SLS431 (Precision Adjustable Reference Source)****印章/Marking : 431****特点/Features :**

- 输入电压范围宽, 可达 36V ;
- 动态输出电阻低, 典型值约为 0.2Ω ;
- 阴极电流能力 1 ~ 100mA ;

用途/Applications :

线性调整电路、可调电源及开关电源电路。

**极限参数/Absolute maximum ratings(Ta=25°C)**

参数/Parameter	符号/ Symbol	数值/Value	单位/Unit
阴极电压/Cathode Voltage	V_{KA}	37	V
阴极电流范围/Cathode Current Range	I_{KA}	-100~100	mA
基准电流输入范围/Reference Input Current Range	I_{REF}	0.05~10	mA
功率/Power Dissipation	P_D	300	mW
使用温度/Operating Temperature	T_{opr}	0~70	°C
储存温度/Storage Temperature	T_{stg}	-65~150	°C

电性能参数/Electrical characteristics (Ta=25°C)

参数	符号	测试条件	最小值	典型值	最大值	单位
基准输入电压	V_{ref}	$V_{KA}=V_{ref}, I_{KA}=10mA$	2.445	2.495*	2.545	V
			2.450	2.500*	2.550	
基准电压温度漂移	$\Delta V_{ref}/\Delta T$	$V_{KA}=V_{ref}, I_C=100\mu A,$ $T_A=0\sim 70^\circ C$		4.5	17	mV
基准与阴极电压变化比率	$\Delta V_{ref}/\Delta V_{KA}$	$I_{KA}=10mA, \Delta V_{KA}=10V\sim V_{ref}$		-1.0	-2.7	mV/V
		$I_{KA}=10mA, \Delta V_{KA}=36V\sim 10V$		-0.5	-2.0	mV/V
基准输入电流	I_{REF}	$I_{KA}=10mA, R1=10K\Omega, R2=\infty$		1.5	4	μA
基准输入电流温度变化率	$\Delta I_{REF}/\Delta T$	$I_{KA}=10mA, R1=10K\Omega, R2=\infty$ $T_A=40\sim 120^\circ C$		0.4	1.2	μA
最小稳压阴极电流	$I_{KA(MIN)}$	$V_{KA}=V_{ref}$		0.45	1.0	mA
OFF 阴极电流	$I_{KA(OFF)}$	$V_{KA}=36V, V_{ref}=0$		0.05	1.0	μA
动态阻抗	Z_{KA}	$V_{KA}=V_{ref}, I_{KA}=1\sim 100mA$ $f\le 1.0KHz$		0.2	0.5	Ω

 V_{ref} 分档/Classification of V_{ref}

档位/Rank	0.5%	1%	2%
范围/Range	2.483~2.507	2.470~2.520	2.445~2.545
	2.487~2.512	2.475~2.525	2.450~2.550

*根据使用要求选择合适的电压规格产品。



SOT-23 精密可调电压基准/SOT-23 Encapsulate Precision Adjustable Reference Source

测试电路 (TEST CIRCUITS) :

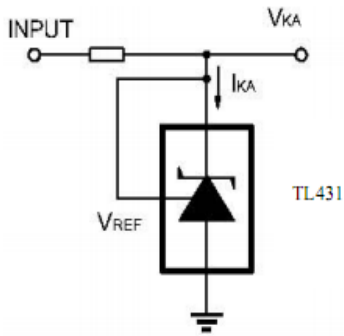

Test Circuit For $V_{KA}=V_{REF}$

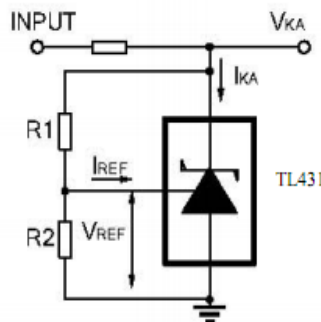

$V_{KA}=V_{REF}(1+R1/R2)+I_{REF}R1$
Test Circuit for $V_{KA} \geq V_{REF}$

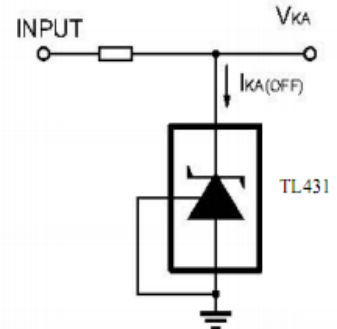

Test Circuit For $I_{KA}(OFF)$

典型应用 (TYPICAL APPLICATION) :

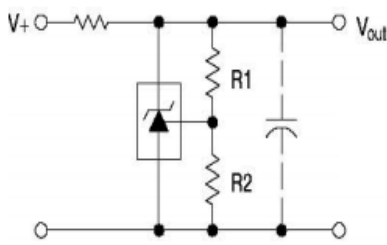

$$V_{out} = \left(1 + \frac{R1}{R2}\right) V_{ref}$$

Shutdown Regulator

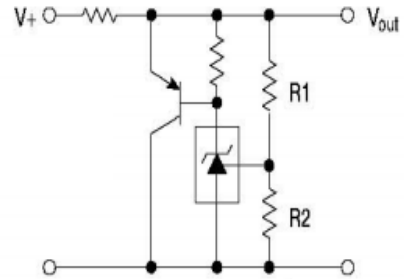

$$V_{out} = \left(1 + \frac{R1}{R2}\right) V_{ref}$$

Higher-current Shunt

典型特性曲线图/Typical Characteristics

Fig 1 Cathode Current Vs Cathode Voltage

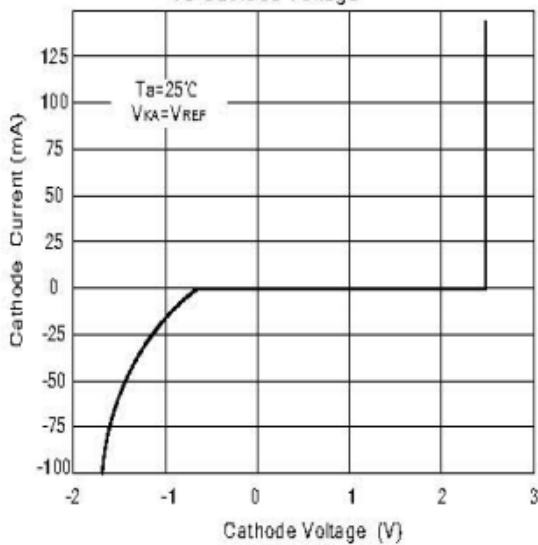
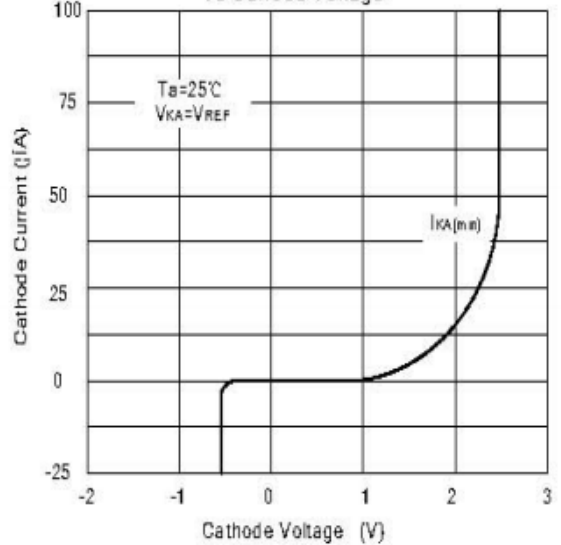

Fig 2 Cathode Current Vs Cathode Voltage





SOT-23 精密可调电压基准/SOT-23 Encapsulate Precision Adjustable Reference Source

Fig 3 Change in Reference Input Voltage Vs Cathode voltage

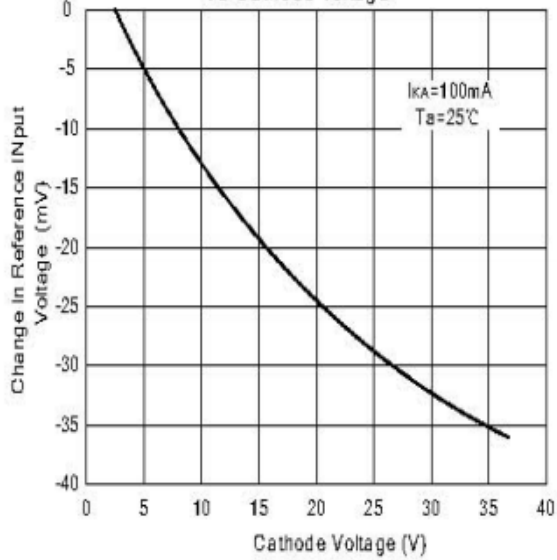

Fig 4 Pulse Response

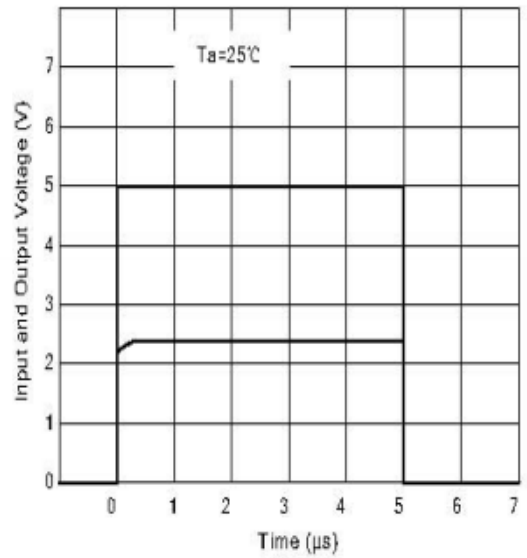

Fig 5 Dynamic Impedance Vs Frequency

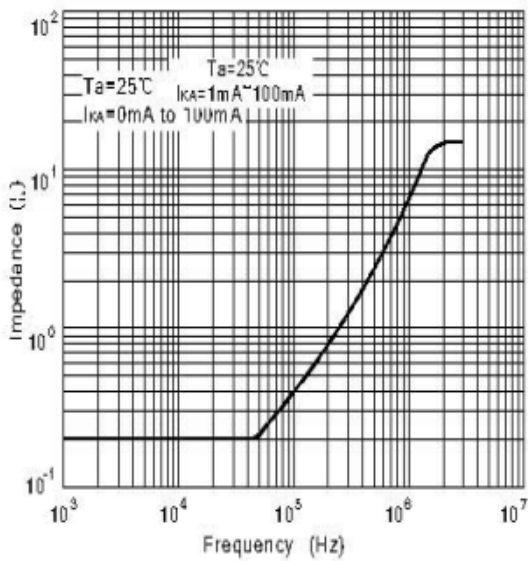

Fig 6 Small Signal Voltage Amplification Vs Frequency

